

CHARACTERISTICS

Deep Cycle Series

Nominal voltage		12V (6 cell per unit)
Nominal capacity at 10 hours rate/10.8V (25°C)		45 Ah
Capacity (25°C)	20 Hours rate/10.8V	47.8 Ah
	5 Hours rate/10.8V	38.4 Ah
Terminal type		M6
Torque		5.1±0.6 N.m
Approx. internal resistance (25°C)		7.5 mΩ
Dimensions	Length	197±2 mm
	Width	165±2 mm
	Height	170±2 mm
	Total height	170±2 mm
Design Life (stand-by)	JIS at 25°C	10 years
	Eurobat at 20°C	10/12 years
Weight		14.3 kg ±3%
Nominal operating temperature		25±3°C
Operating temperature range	Discharge	-15°C~50°C
	Charge	-10°C~50°C
	Storage	-20°C~50°C
Float charging voltage at 25°C		13.5V~13.8V
Cyclic charging voltage at 25°C		14.5V~15.0V
Temperature compensation	Float charge	-18 mV/°C/Block
	Cycle charge	-30 mV/°C/Block
Max. charging current (A)		12A
Max. discharge current for 5 seconds		400A
Self discharge rate (25°C)		≤3%/month
Battery container ABS UL94-HB		V-0 optional

DIMENSIONS & TERMINAL TYPE (MM)

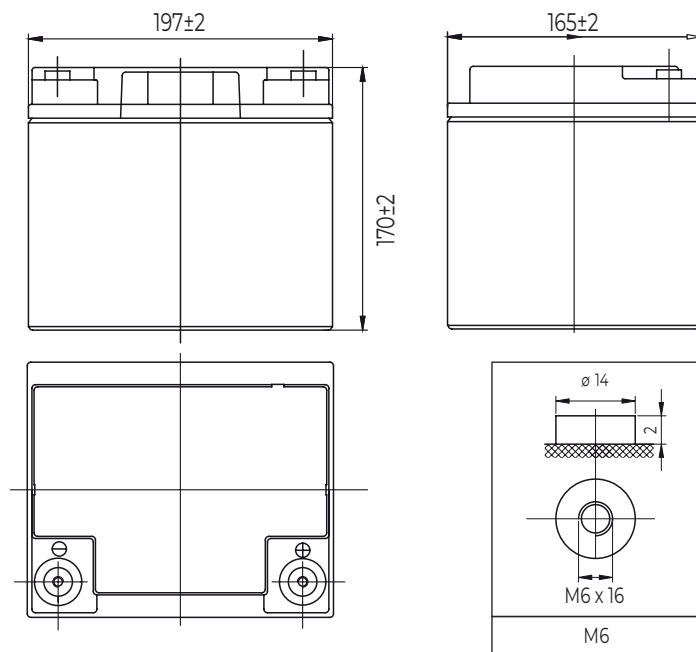

CERTIFICATION & COMPLIANCES



Compliant to: EUROBAT, RoHS, WEEE's and Reach.
Manufactured according to IEC 60896-21 / 22

CONSTRUCTION

Component	Positive Plate	Negative plate	Container	Separator	Electrolyte	Safety valve	Terminal
Raw material	Lead dioxide	Lead	ABS (V-0 opt.)	AGM	Sulfuric Acid	Rubber	Copper

CONSTANT CURRENT DISCHARGE CHARACTERISTICS AT 25°C

(Ampere/battery)

F.V/Time	10min	15min	30min	60min	2h	3h	4h	5h	8h	10h	20h
9.60V	100	77.1	46.1	28.4	16.4	11.8	9.46	8.08	5.55	4.58	2.43
9.90V	97.1	75.3	45.2	27.9	16.3	11.8	9.40	8.03	5.52	4.57	2.42
10.2V	93.1	72.5	43.8	27.2	16.2	11.7	9.33	7.98	5.48	4.56	2.42
10.5V	89.1	70.0	42.8	26.4	16.0	11.6	9.27	7.92	5.45	4.53	2.40
10.8V	84.1	66.3	41.2	25.5	15.6	11.3	8.99	7.68	5.28	4.50	2.39

CONSTANT POWER DISCHARGE CHARACTERISTICS AT 25°C

(Watts/battery)

F.V/Time	10min	15min	30min	60min	2h	3h	4h	5h	8h	10h	20h
9.60V	1081	847	518	323	190	139	111	95.5	66.0	54.7	29.1
9.90V	1048	826	507	319	189	138	111	94.9	65.6	54.6	29.1
10.2V	1005	796	492	310	188	137	110	94.3	65.1	54.4	29.0
10.5V	962	769	480	301	185	137	109	93.6	64.7	54.1	28.8
10.8V	908	728	462	291	180	132	106	90.8	62.7	53.7	28.6

The above characteristics represent average values and can be obtained within three charge and discharge cycles. The batteries must be fully charged before testing. The data in this document is subject to change without notice and become contractual only after written confirmation. Please contact Avacom for the latest available version.